

Proses Vanaları

Process Valves



SKV Serisi Bıçaklı Sürgülü Çamur ve Proses Vanaları

SKV Series Knife Gate
Mud and Process Valves



SKV Serisi Bıçaklı Sürgülü Çamur ve Proses Vanaları

SKV Series Knife Gate Mud and Process Valves

Uygulama Alanları

- Apýndýrýcý ve yapýpkan maddeler içeren, katý, lifli, yüksek yoðunluklu akýpkanlarýn tapýndýðý terfi hatlarýnda kýsma, açma, kapama ve kontrol amaçlý kullanýlan vanalardýr
- Manuel ve otomatik kumanda edilebilme özelliði, tam açýk konumda sýfýr kayýp etkisi ile arýtma tesisleri, kimyasal proses tesisleri vb yerlerde güvenle kullanýlabilirler

Teknik Özellikler

Anma Çaplarý	: DN 50 - DN 600
Basýnç	: PN 10
Sýcaklýk aralıðý	: -15 ~ 140 ° C
Standart malzeme	: Gövde — GGG40 Klape — 1.4301 Conta — PTFE

Proses sývysý özelliklerine göre alternatif malzeme uygulamalarý yapılabilmektedir

Kodlama

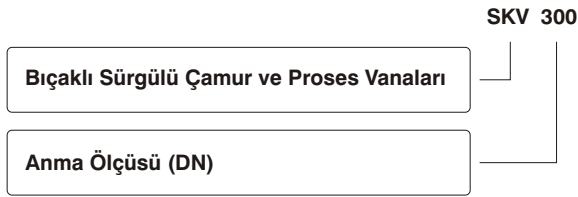

Application Fields

- They are used to control the flow of the aggressive and/or sticky, viscous fluids even including solid and fibrous particals.
- Their automatic and manuel control options and zero head loss at full open position , makes them very reliable to be used for waste water treatment and transfer systems and chemical process plants.

Technical Specifications

Nonimal Diameters	: DN 50 - DN 600
Pressure	: PN 10
Temperature Limits	: -15 ~ 140 ° C
Standard Materials	: Body — GGG40 Knife — 1.4301 Gasket— PTFE

Depending on the process fluid, different costruction materials can be applied

Coding

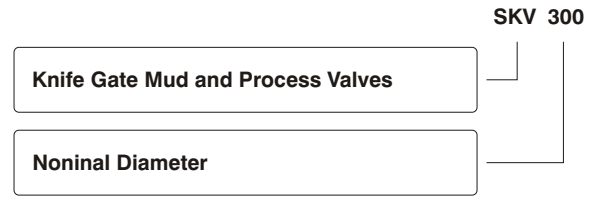

Ölçüler / Dimensions

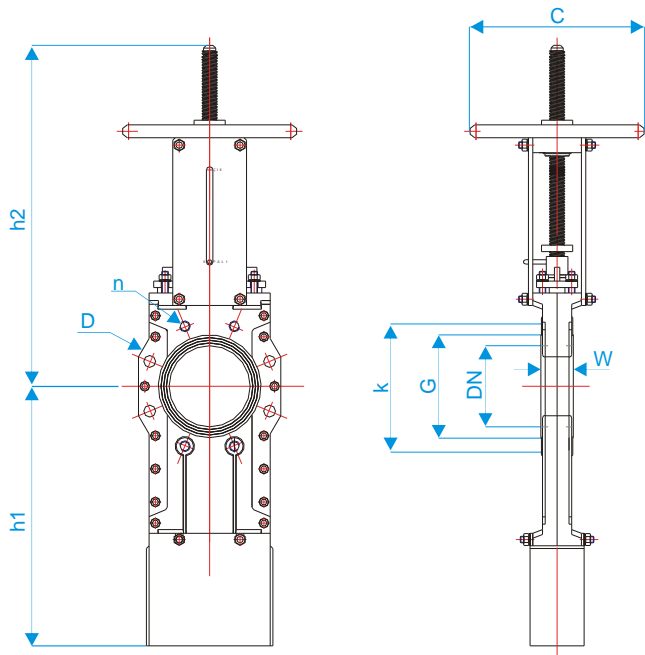

SKV Ölçüler / SKV Dimensions

50	165	125	4	102	50	225	415	250	25
80	200	160	8	138	54	284	475	250	32
100	220	180	8	158	54	325	548	325	50
150	285	240	8	212	60	465	685	325	65
200	340	295	8	268	74	595	800	390	97
250	395	350	12	320	74	720	935	400	158
300	445	400	12	370	80	833	1050	400	220
350	505	460	16	430	80	980	1200	500	300
400	565	515	16	482	95	1070	1330	500	310
500	670	620	20	585	120	1330	1615	500	430
600	780	725	20	685	120	1540	1880	500	670



**tecrübe ve kalite
bu adreste**

Fabrika / Factory:
10014 Sk. No.7
A.O.S.B
Çiöli - Ýzmir / TÜRKÝYE

Telefon / Phone:
+90 (232) 376 74 28 (pbx)
Faks / Fax:
+90 (232) 376 80 54

www.goksan.com.tr
info@goksan.com.tr

**experience
and quality
is here**



 **Göksan Pompa Sanayi ve Ticaret Anonim Şirketi**
Goksan Pump Industry INC.

SEPA